

# WeighStation™ Track Scale

## Meter Display

Model No. WS-21M

### • Prototypical Track Scale for model railroad operations

- Displayed weight (lbs.) varies from car to car within user-defined range
- 3 selectable ranges for car variety or Loads/Empties/Scale Test
- Realistic display action as cars move on and off the scale
- Optional LED and bell alert when weighing is complete
- Optional red & green LED "traffic light" to guide train crews
- **NightScope™ Infrared Detector** for day or night operation
- Supports both Weigh In Motion and Static weighing operation

### • Simple installation

- Gantlet or single track arrangement
- Faceplate/Circuit Assembly with Fascia Template for clean installation
- Screw terminals for all circuit board connections
- Power Supply: DC (9-12 V) or AC (7-9 V), 50 mA **required**

### • Parts List

- **WeighStation™ Track Scale** Faceplate/Circuit Assembly
- **WeighStation™ Track Scale** Meter Assembly
- **NightScope™ Infrared Detector**
- Piezoelectric Bell Assembly
- Fascia Template

**Notice: This product simulates weighing for model railroad operations, and does not provide the true weight of rail cars.**

### Before You Install

- Your **WeighStation™ Track Scale** can be damaged by static electricity. Before removing the circuit board from its packaging, discharge static electricity by touching a bare metal surface.
- Do not make connections when circuits are powered.
- Insulate all exposed connections, preferably with heat shrink tubing.
- Prevent contact between your Track Scale and track wiring.
- Read through the rest of these instructions before beginning.
- Visit [www.bouldercreekengineering.com](http://www.bouldercreekengineering.com) for additional information.

### Gantlet or Single Track?

Prototype railroads have historically used a gantlet track arrangement to keep heavy locomotives off delicate track scales. See Figure 1. Today, railroads install track scales directly on single track with electronic load cells robust enough to support slow moving locomotives. Even so, gantlet track scales are still widely used.

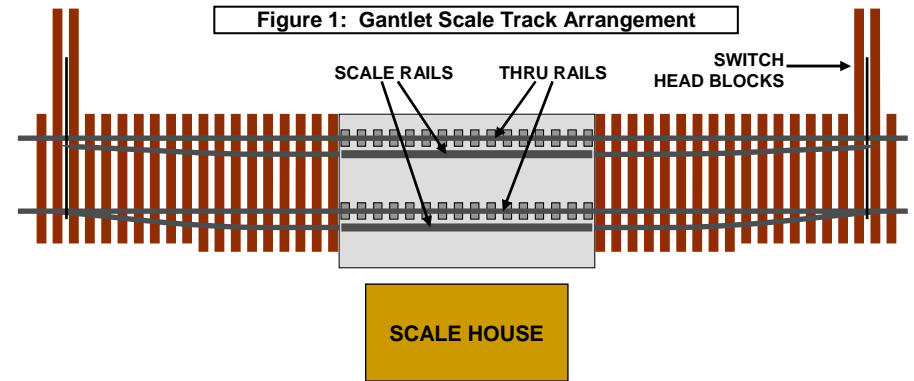

The **WeighStation™ Track Scale** will support either single track or gantlet track installations. If you install on single track, use the WEIGH switch on the Track Scale faceplate to turn the scale on and off. See Figure 2. If you install a gantlet track, simply leave the WEIGH switch on.

Walthers offers a structure kit (933-3199) for gantlet scale tracks, and the September 2002 and April 2009 Model Railroader magazines feature gantlet track scale projects.

Figure 2: Faceplate Controls

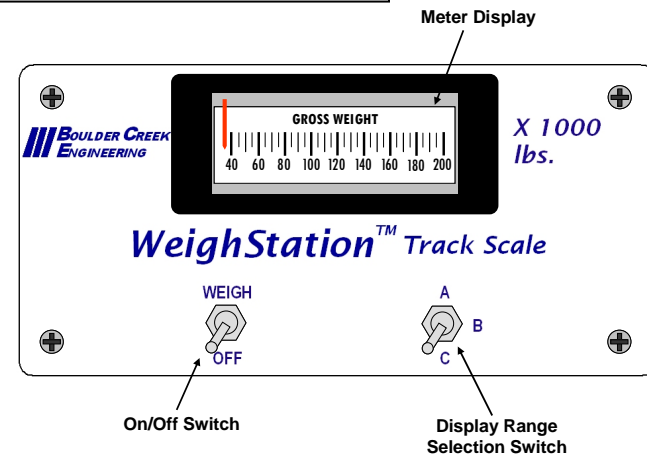

# Installation Instructions

(Visit [www.bouldercreekengineering.com](http://www.bouldercreekengineering.com) for step-by-step photos.)

1. Select the location for your **WeighStation™ Track Scale**. You will need a 3" by 6" space on your fascia for the Track Scale Faceplate/Circuit Assembly, with at least 3" clearance behind it.
2. Install the **NightScope™ Infrared Train Detector** at the mid point of the scale track following its packaged instructions. Use the physical alignment described in either a or b below:

- a. If you are installing as a single track, install the Detector between the rails as in the Detector instructions.
- b. If you are installing as an HO gantlet track, install the Detector as shown in Figure 3, following the steps in the Detector instructions.

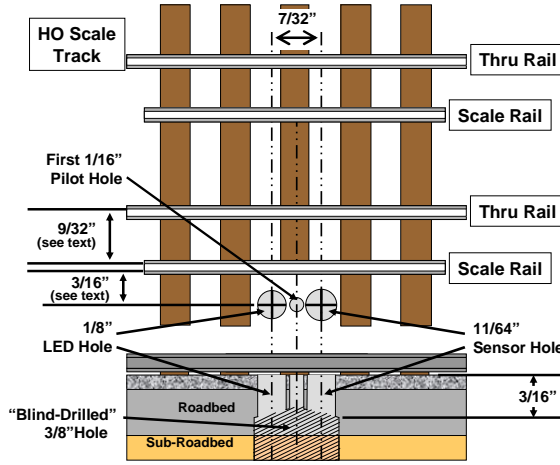

Figure 3: Detector Installation for Gantlet Track

- The Scale Rail should be a scale 24" from the Thru Rail. Thus in HO Scale the rails are 9/32" apart as shown, and in N Scale the rails will be 5/32" apart. While 3" wider than the prototype, 24" is needed between the rails due to the variation in model rail car widths. The Detector hole centers are 3/16" from the outside edge of the outside Scale Rail in HO, 3/32" for N Scale.
3. Use the included Fascia Template to mark the screw and display holes on your fascia. The template shows clearance holes for No. 4 machine screws – smaller holes (or none at all) are needed for wood screws.
  4. Cut out the display hole; drill the screw holes if needed.
  5. Install the Meter Assembly into the Faceplate/Circuit Assembly as shown in Figure 4. The Meter face protrudes through the faceplate.
  6. Connect the RED and BLACK wires from the Meter Assembly to the Track Scale Faceplate/Circuit Assembly as shown in Figure 5.
  7. Remove paperclip (or wire) from screw terminals on back of meter.

8. Mount the Track Scale Faceplate/Circuit Assembly to your fascia with No. 4 pan-head screws (not included).
9. Mount the optional Piezoelectric Bell Assembly in or near your scale house, or on your fascia. Drill two 3/32" holes 3/8" apart at your chosen location to thread the wires. If needed, a drop of ACC on each of the bottom mounting pins will hold it in place.

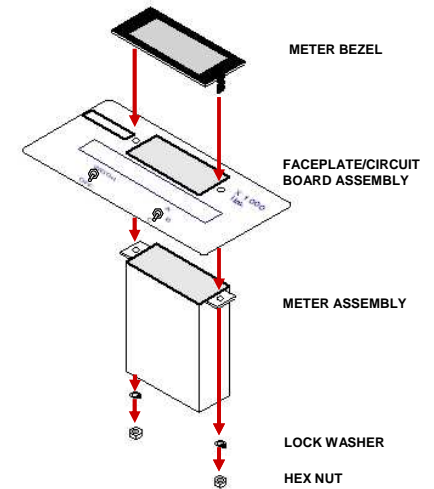

Figure 4: Installing the Meter

# Wiring Instructions

Figure 5 shows how to wire your **WeighStation™ Track Scale**, along with key features on the circuit board. (Meter connections were made previously in step 6 above.)

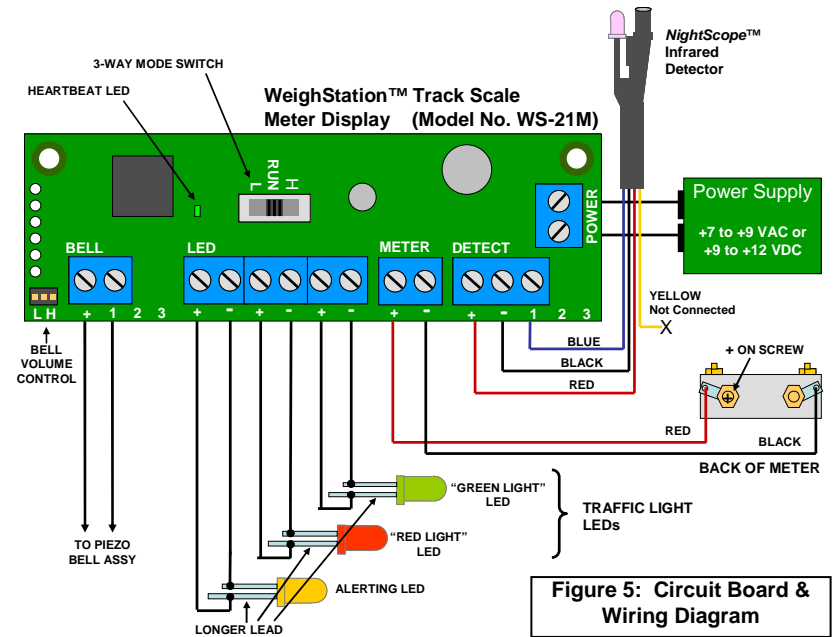

Figure 5: Circuit Board & Wiring Diagram

1. Connect two wires from your power supply to the Track Scale power terminals as shown in Figure 5. Polarity does not matter. The power supply must be 7 to 9 Volts AC or 9 to 12 Volts DC, with 50 mA capacity. Radio Shack sells an AC adapter (#273-314) that works well.

**Warning: Do not exceed 9 Volts AC or 12 Volts DC as this will damage the circuit board.**

2. Connect the RED, BLACK and BLUE wires from the **NightScope™ Infrared Train Detector** as shown in Figure 5. The YELLOW wire is not used – trim it and insulate the end.
3. If you are using the Piezoelectric Bell Assembly, connect it as shown in Figure 5. Polarity does not matter.
4. You can directly wire an Alerting LED as in Figure 5. Install the LED on or near your Scale House. Or you can install the red and green “traffic light” LEDs as shown. (LEDs are not included.) LEDs are polarity sensitive – connect the long and short leads as shown. The Track Scale circuit board sources 20 mA at 2 Volts for each LED.

**Warning: Do not connect an LED or other circuitry exceeding 20 mA at 2 Volts as this will damage the circuit board.**

## Operation

Upon power up, the **WeighStation™ Track Scale** momentarily displays the low and high Display Range values for the currently selected range. This range may be adjusted as described in “Setting Display Ranges”.

The Track Scale Circuit Board has a green “Heartbeat LED” (see Figure 5) that blinks every second while the Track Scale is waiting for a car. It is steadily on while the Track Scale is generating a car weight, or while setting the Display Range.

For single track installations, the On/Off Switch (see Figure 2) initiates the weighing operation. It should be set to “WEIGH” when weighing is desired, and set to “OFF” when it is not. For gantlet track installations, the On/Off Switch should always be set to “WEIGH”.

Before weighing, set the Display Range Selection Switch to the desired range. See “Setting Display Ranges” for description of the factory programmed ranges and how to modify them for your operation.

With the 3-Way Mode Switch in the **RUN** position, the Track Scale performs as follows:

1. Scale active but unoccupied. [Optional “traffic light” LEDs are Green.]
2. When a rail car is spotted on the active scale track, the scale waits a moment before beginning to display. [Green]

3. The weight displayed ramps up authentically to a random weight in pounds (lbs) within the selected Display Range. [Red]
4. Shortly after weight reading stabilizes, the Alerting LED lights and the Piezo Bell sounds to alert the train crew to spot the next car. [Green]
5. As soon as the car is removed, weight displayed ramps down. [Green]
6. Cycle 2 – 6 repeats with spotting of next rail car.

The Track Scale responds quickly enough at prototypical speeds (less than 5 miles per hour) for “weigh in motion” operations.

Visit [www.bouldercreekengineering.com](http://www.bouldercreekengineering.com) for operating ideas, paper forms, and other materials for integrating rail car weighing into your operations.

## Defining a Display Range

Your **WeighStation™ Track Scale** has three Display Ranges, selected by setting the Display Range Selection Switch on the Faceplate (see Figure 2). The Track Scale is factory programmed with Display Ranges approximating:

- A) Loads – “normal” operating mode.
- B) Empties – typical weight of empty rail cars.
- C) Test – displays slightly varying weight of a scale test car.

You may use these Display Ranges or you may modify them to create Display Range settings to fit your operations.

For example, you may want to have: A) a fairly tight range for weighing single commodity cars of similar capacities (like coal hoppers), B) a second wider range for all other loaded cars, and C) a single-value range (like the factory setting) for your scale test car.

Choose weight limits for a Display Range based on the data stenciled on the cars you intend to weigh with that Display Range. Using coal hopper cars as an example, find the hopper with the smallest **load limit**. Add the **light weight** to the **load limit** – this will be the absolute maximum **gross weight** for your coal hopper cars. If your smallest hopper has a load limit of 125,200 lbs. and a light weight of 43,800 lbs. (typical for 50-ton hoppers), your maximum gross weight would be 125,200 + 43,800 = 169,000 lbs. Thus a 170,000 lbs. maximum weight limit would be appropriate for this range.

For a minimum, coal hoppers will be filled to at least 95% of their nominal **capacity** – 95,000 lbs. for a 50-ton hopper. Add the **light weight** of 43,800 lbs: 95,000 + 43,800 = 138,800 lbs., which rounds to 140,000 lbs. Thus 140,000 to 170,000 lbs. would be reasonable for this Display Range.

Similarly, you could define Display Ranges for other car types. Industry data shows that rail cars carry an average of about 60 to 70 percent of their rated **capacity**. This average includes the near-**capacity** loading of single commodity cars like coal hoppers, which brings the average up. So if you are defining a Display Range for a miscellaneous collection of loaded cars, center your range lighter than 60 to 70 percent of **capacity**, but feel free to keep minimum and maximum limits fairly wide.

### Setting Display Ranges

Use the 3-Way Mode Switch in the center of the circuit board (see Figure 5) to set the three Display Ranges as follows:

1. Select the Range (A, B, or C) that you wish to set with the Display Range Selection Switch (see Figure 2).
2. The Mode Switch is normally kept in the **RUN** position.
3. Slide the Mode Switch to the **LO** position:
 

The Meter Display counts up from 0 until the user slides the Mode Switch to RUN.
4. When the desired weight is reached, slide the Mode Switch to **RUN**:
 

The last displayed weight will be **minimum** weight limit for this range. Low and high weight limits for this range are momentarily displayed to confirm the selection.
5. Slide the Mode Switch to the **HI** position:
 

The Meter Display counts down from the maximum weight shown on the scale face until the user sets Mode Switch to RUN.
6. When the desired weight is reached, slide the Mode Switch to **RUN**:
 

The last displayed weight will be **maximum** weight limit for this range. Low and high weight limits for this range are momentarily displayed to confirm the selection.
7. Repeat steps 1 through 6 to set the other ranges as desired.

**Note:** You cannot set a maximum weight limit lower than the current minimum weight limit, or a minimum weight limit higher than the current maximum weight limit. You may need to change one limit before the other to avoid this restriction.

### Setting Bell Sound Volume

The Bell sound volume is controlled by the black jumper in the lower left corner of the circuit board (see Figure 5). Slip the jumper over the center and “L” terminals for a lower volume, or over the center and “H” terminals for a higher volume. To turn off the Bell, remove the jumper.

### Support & Service

If you have problems with your **WeighStation™ Track Scale**, please consult our website [www.bouldercreekengineering.com](http://www.bouldercreekengineering.com). If you need additional help, please contact us at [support@bouldercreekengineering.com](mailto:support@bouldercreekengineering.com).

Your Track Scale can be repaired with a charge for parts and labor. Please contact [support@bouldercreekengineering.com](mailto:support@bouldercreekengineering.com) for a cost estimate on non-warranty repairs before sending product to us.

### Limited Warranty

Boulder Creek Engineering, LLC warrants its products to be free of defects in materials and workmanship for a period of **one (1) year** from the purchase date. Defective product received by Boulder Creek Engineering during the warranty period will be repaired or replaced at our option. You must pay shipping to and from Boulder Creek Engineering.

This warranty does not cover damage resulting from negligent installation, improper operation, or unauthorized repair or modification. Removal of the heat shrink voids this warranty. Boulder Creek Engineering makes no other warranty of any kind, expressed or implied. In no event shall Boulder Creek Engineering be liable for incidental or consequential damages.

For warranty service, please contact Boulder Creek Engineering for a Return Merchandise Authorization (RMA) number. Product must be shipped to Boulder Creek Engineering with dated proof of purchase (your receipt).



2525 Arapahoe Ave.  
Suite E4-605  
Boulder, CO 80302

(303) 443-5784  
[support@bouldercreekengineering.com](mailto:support@bouldercreekengineering.com)