

TrainBoss™ Defect Detector

Talking Detector

Model No. TB-21T

Hotbox & Equipment Defect Detector for model railroads

- Voice report or visual display options to match your railroad era:
 1. Modern **automated trackside** voice reports (1980s – Today)
 2. **Trackside** and **remote operator displays** (1940s – Today)
 3. **Train crew** voice reports (all eras)
- Speaks/displays 6 types of defect alarms for passing trains: hotbox, dragging equipment, high car, wide or shifted load, sliding wheel
- Reports train axle count, speed and length, and total axle count per session
- **User defined** voice reports to match your prototype
- **User defined** alarm probability for each defect type, 1/30 to 1/8000 cars
- Infrared Axle Sensors support day and night operation in all scales
- Volume-controlled speaker output and stereo jack for powered speakers
- 200 mA alerting outputs drive LEDs, motors, relays, or other railroad electronics
- Inputs to 1) Repeat last message, 2) Force alarm on next train, 3) Clear alerts

Simple installation

- One-piece Axle Sensors slip under installed track and simplify correct alignment
- Screw terminals for all circuit board connections
- Factory configured for immediate use
- Polarity-independent DC (9-12 V) or AC (7-9 V), 250 mA **required**
- 8-Ohm speaker or powered speakers **required**

Parts List

- **TrainBoss™ Defect Detector** Circuit Board
- Infrared Axle Sensors (2)
- Repeat Push Button Switch
- Fascia Template
- Vinyl Tubing for Standoffs

Notice: This product simulates defect detection for model railroads and does not sense the true condition of rail cars.

Before You Install

- Your **TrainBoss™ Defect Detector** can be damaged by static electricity. Before removing the circuit board from its packaging, discharge static electricity by touching a bare metal surface.
- Do not make connections when circuits are powered.
- Insulate all exposed connections, preferably with heat shrink tubing.
- Prevent contact between your Defect Detector and track wiring.
- Read through the rest of these instructions before beginning.
- Visit www.bouldercreekengineering.com for additional information.

1. Installing Axle Sensors

Only one Axle Sensor is needed for your **TrainBoss™ Defect Detector** to produce alarms. Add the second sensor for train speed and length reports.

1. Select the location for your Axle Sensors. A straight section of avoids rail car interference problems that long equipment may have on curves.

Close incandescent lighting will interfere with proper Axle Sensor operation. **40 W bulbs within 12 inches will block proper detection.**

2. If you are installing two Axle Sensors, you can install them from 4 to 235 scale feet apart. Over 20 feet is recommended. (The factory setting is 44 feet; change the separation in SV 7 if you choose another spacing.)

You can install Axle Sensors before or after installing your track. Refer to either Step 3 or Step 4 to match your situation.

3. Installing the Axle Sensor before installing the track:
 - a. Refer to **Figure 1** for correct Axle Sensor positioning for your scale.
 - b. Carefully bend the Axle Sensor's LED to face the Infrared Sensor.

Warning: Bending the LED more than once can break the LED.

- c. Position the Axle Sensor, mark and drill a 3/16" hole for the wires through the roadbed.
- d. Thread the wires through the hole.
- e. Remove ties as necessary and lay the track over the Axle Sensor.
- f. Go to Step 5.

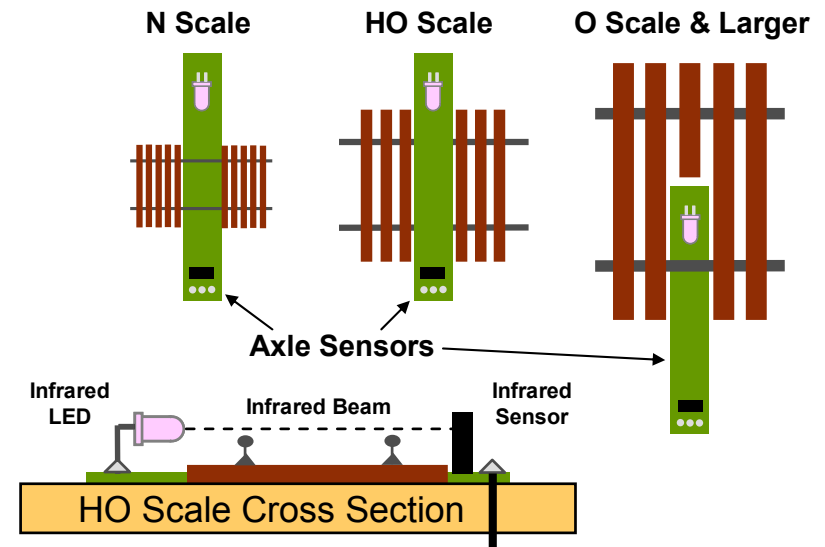

Figure 1: Axle Sensor Alignment

4. Installing the Axle Sensor after installing the track:
 - a. Power down your track.
 - b. Refer to **Figure 1** for correct Axle Sensor positioning for your scale.
 - c. Remove ties from the track as necessary.
 - d. Drill a 1/4" hole in the roadbed beneath the track and partially or completely across the rails as in **Figure 1**.
 - e. Cutting with a knife, extend the roadbed hole to the roadbed surface.
 - f. Position the Axle Sensor, mark and drill a 3/16" hole for the wires through the roadbed.
 - g. With the LED leading, slide the Axle Sensor under the rail(s).
 - h. Thread the wires through the 3/16" hole.
 - i. Carefully bend the Axle Sensor's LED to face the Infrared Sensor.

Warning: Bending the LED more than once can break the LED.
5. Align the LED to just clear the top of the rail as in the "HO Scale Cross Section" of **Figure 1**. Check that rail cars clear the Axle Sensor.
6. We will test the Axle Sensor(s) later in the installation. Do not glue Axle Sensors in place until your installation is complete and tested.

2. Choosing an Installation Option

Your **TrainBoss™ Defect Detector** can be configured to match one of three operating eras. Two eras feature voice reports, while the third era offers two visual display options. Choose your option before installing.

Automated Trackside Voice Reports (1980s – Today)

This option simulates today's defect detector reports heard on radio scanners. Your Defect Detector can be customized to match a prototype. Each passing train receives a voice message with train status or a defect alarm. Pressing the **Report** push button repeats the message.

As shown in **Figure 2**, the Defect Detector circuit board is mounted on benchwork below the roadbed and near the Axle Sensors and speakers.

For this option, continue with **Section 3, Installing the Circuit Board**.

Train Crew Voice Reports (all eras)

Traditionally, train crews kept a look out for equipment defects from the engine cab and caboose. They alerted the engineer to stop the train (using an air whistle from the caboose if necessary) and then met to talk over the problem and a fix. In this option, your Defect Detector sounds two short whistles to stop the train. The **Report** push button starts the crew report.

As in the previous option, the Defect Detector circuit board is mounted near the Axle Sensors and speakers as shown in **Figure 2**.

For this option, continue with **Section 3, Installing the Circuit Board**.

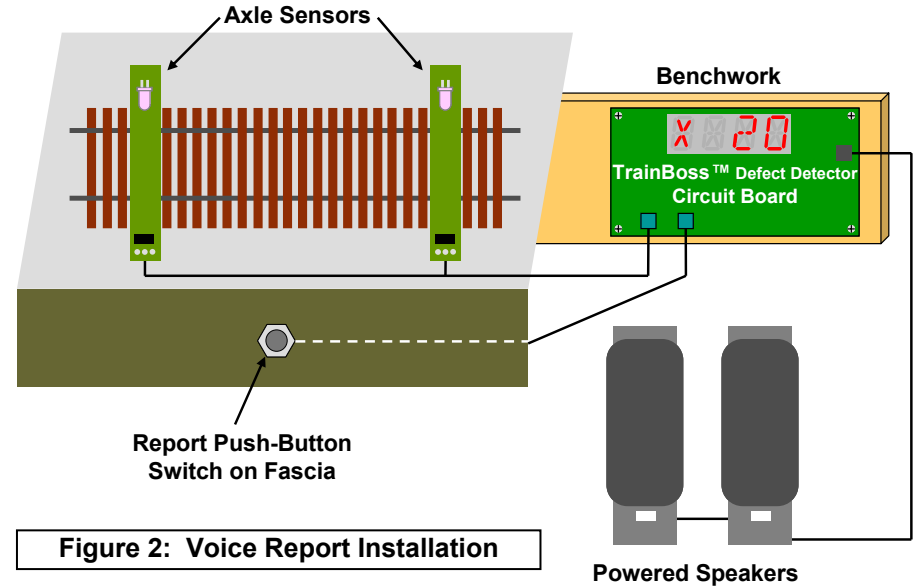

Figure 2: Voice Report Installation

Trackside or Remote Visual Display (1940s – Today)

Starting in the 1940s, railroads began to automate train defect detection without recorded voice reporting.

For this option, please visit our website (www.bouldercreekengineering.com) and follow the **Installing TrainBoss™ Talking Defect Detector for Display Only** guide on our Manuals page.

3. Installing the Circuit Board

Mount the **TrainBoss™ Defect Detector** circuit board under your layout near the Axle Sensor(s) as shown in **Figure 3**. Slice 1/4" standoffs from the vinyl tubing provided. The screw holes in the circuit board are for No. 4 pan-head screws (not included).

Warning: Do not enlarge the circuit board holes or over-tighten the mounting screws as this will damage the circuit board.

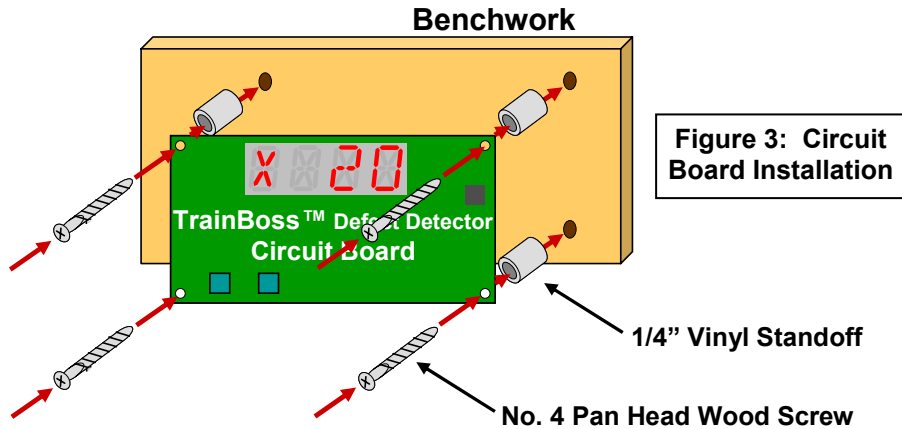

Figure 3: Circuit Board Installation

4. Wiring Instructions

Figure 4 shows how to wire your **TrainBoss™ Defect Detector** for voice reporting, along with key features on the circuit board.

1. Connect two wires from your power supply to the Defect Detector power **gray** terminals as shown in **Figure 4**. Polarity does not matter. The power supply must be 7 to 9 Volts AC or 9 to 12 Volts DC, with 250 mA capacity. Radio Shack sells an AC adapter (#273-314) that works well.

Warning: Do not exceed 9 Volts AC or 12 Volts DC as this will damage the circuit board.

Warning: Do not share an AC Adaptor with other electronics as this will lead to humming or buzzing interference in the audio output.

2. Connect the RED, BLACK and YELLOW wires from the Axle Sensors as shown in **Figure 4**.
3. If you are installing the speed/length Axle Sensor, **remove Jumper J9**.
4. You can wire Alerting LEDs as in **Figure 4**. LEDs are polarity sensitive – connect the long and short leads as shown. Visit

www.bouldercreekengineering.com/manuals.php for information on how to interface other electronics to these two outputs. (LEDs not included.)

5. The **Report** Switch triggers or repeats a defect report. Connect the push button **Report** Switch (included) as shown in **Figure 4** and mount on your fascia.
6. The **Next Train** Switch forces a defect report on the next train when pressed, which is nice for testing. If desired, connect a push button **Next Train** Switch (n. o. type – not included) as shown in **Figure 4**.
7. Grounding **Clear Outputs** will clear LED Outputs 1 and 2. Visit our website (www.bouldercreekengineering.com/manuals.php) for information on how to interface other electronics to this input.
8. Connect either an 8 ohm speaker to the **SPEAKER** terminal block or connect powered speakers with a 1/8" stereo plug to the **LINE** jack. Powered speakers are highly recommended as they provide much better sound quality and are available for about \$10 from Dell and other Internet sources. (**Speakers are not included.**)

Warning: Connecting a speaker rated less than 8 ohms to the SPEAKER terminal block will damage the circuit board.

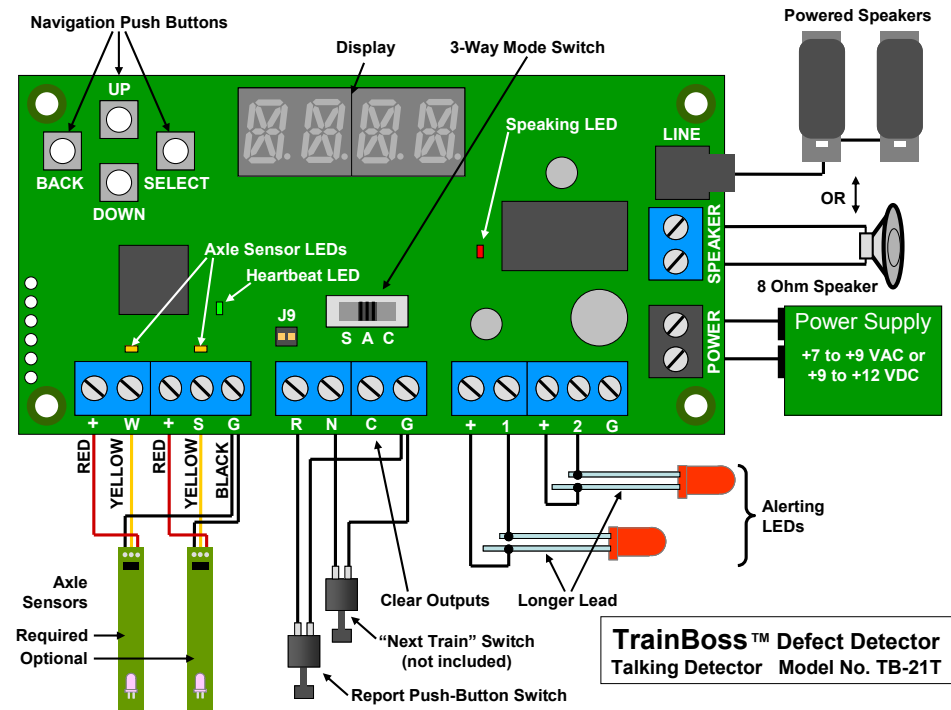

Figure 4: Circuit Board & Wiring Diagram

5. Testing Your Installation

1. Apply power to your **TrainBoss™ Defect Detector**. The Heartbeat LED should blink once every second. Check your power wiring if it does not.
2. Axle Sensor LEDs should be off. Check Axle Sensor alignment if not.
3. Set the 3-Way Mode Switch to “A”.
4. Break the infrared beam(s) by passing your finger along the track. The Axle Sensor LEDs should flicker. Check your wiring if they do not.

You will hear an automated voice report in a few seconds.

5. Repeat Step 4 by running a train. If axle count is correct, glue your “W” sensor in place. **Allow 48 hours for water-based glue to thoroughly dry before connecting to your Defect Detector.**

If axle count is not correct, check the alignment of the “W” Axle Sensor. The infrared beam should just clear the railhead as in **Figure 1**.

If you receive a speed and length report, glue your “S” sensor in place. Be sure to program SV 7 (see **Section 8**).

If you do not receive a speed or length report, check the alignment of the “S” Axle Sensor. The infrared beam should just clear the railhead as in **Figure 1**. Also check your wiring.

6. **Congratulations**, your Defect Detector is now operational!

6. Basic Operation

6.1 Operating Modes and Mode Switch Positions

The 3-way Mode Switch positions are labeled S, A, and C. See **Figure 4**. Changing the switch position immediately puts the Defect Detector into a new mode:

S = SETTINGS – Settings Mode (see **Section 7**)

A = AUTOMATED – Automated Trackside Voice Reports Mode
(see **Section 6.2**)

C = CREW – Train Crew Voice Reports Mode (see **Section 6.3**)

The Defect Detector Circuit Board has a green “Heartbeat LED” that blinks every second while waiting for a train in **A** or **C**. It is steadily on other times. The red “Speaking LED” flashes when the Detector is speaking messages.

6.2 Automated Mode Operation

With the 3-Way Mode Switch in the **A** position, the Defect Detector will speak an automated message 5 seconds after a train passes. If all is well, status is

spoken, which may include axle count, speed, and train length. Otherwise, a defect type and axle are spoken. Push the **Report** Push Button to repeat.

6.3 Crew Mode Operation

With the Mode Switch in the **C** position, the Defect Detector will speak as a train crew member (with railroad slang) 5 seconds after a train passes. If all is well, an “all clear” is given. Otherwise the crew gives two toots on the air whistle to stop the train. (This is per Rule 16b in the Consolidated Operating Rules.) Pushing the **Report** Push Button will start or repeat the report. Defect reports include hot boxes, dragging equipment and speed warnings.

6.4 Displayed Information

While speaking, the Defect Detector will also briefly display axle count, speed, length, and temperature – in that order – if there are no defects. In case of a defect, a one letter defect code is given as shown in the following table, along with the axle location. **Figure 5** shows a Hotbox on axle 120, north or east rail.

Letter	Defect Type
X	Hot box
D	Dragging Equipment
S	Sliding Wheel
H	High Car
W	Wide Load
L	Shifted Load

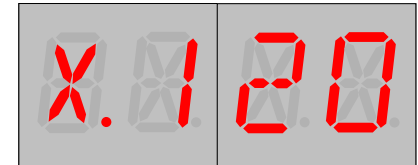

Figure 5: Axle 120 Hotbox, with north or east rail indicated by decimal point

6.5 Volume Adjustment

To increase or decrease speech sound volume, press SELECT with the 3-Way Mode Switch in the **A** or **C** position while waiting for a train. There are eight volume levels; each push of SELECT moves volume incrementally up to the maximum, then down to the minimum, then back again.

For powered speakers, set your Defect Detector to a medium volume and make final volume adjustments with the speaker controls.

6.6 Error Messages (see SV 15, Bit 7 in Section 8)

Spoken Message	Display	Meaning
“Malfunction”	*ERR	Starting/stopping/reversing trains close to the Axle Sensors has reset the Detector
“Sensor Blocked”	*DET	The “W” Axle Sensor is blocked by a railcar upon power up or reset

7. Settings Mode Operation

7.1 Settings Mode Basics

While your **TrainBoss™ Defect Detector** works right out of the box, you can customize its performance by changing the values of its Setting Variables (SVs). SVs are similar to Configuration Variables (CVs) for DCC decoders. SVs set up the voice messages for passing trains, determine the behavior of connected LEDs, and set the average number of cars between defects. There is even an SV that turns on or off railroader slang in train crew reports! Section 8 describes the SVs available for your Defect Detector.

Upon selecting **S** with the 3-way Mode Switch, the Defect Detector enters Settings Mode and will show SV 1, but not a value, on the Display. See **Figure 6a**. Axle Sensors are ignored while in Settings Mode.

While in Settings Mode, the Display shows the number of the current SV, followed by a decimal point. (See **Figure 6a**.) A value for an SV is shown to the right of this decimal point. (See **Figure 6c**.) If this value is the currently stored value for the SV, there is another decimal point to the right of the value. (See **Figures 6b** and **6d**.) Selecting either the **A** or **C** position on the 3-way Mode Switch will exit Settings Mode. The Defect Detector will immediately begin operation.

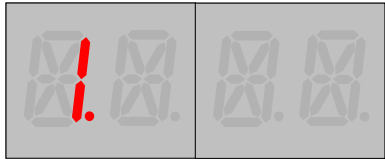

Figure 6a: Entering Settings Mode. SV 1 is displayed with decimal point to the right. No value shown while navigating among SVs.

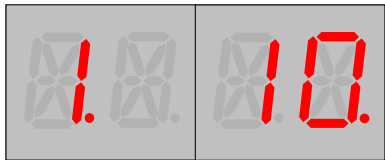

Figure 6b: SV with its stored value. SV 1 has a stored value of 10. Stored value is indicated with decimal point to the right of the value.

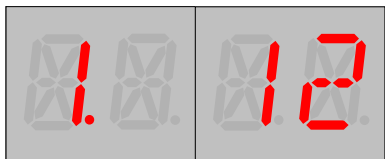

Figure 6c: SV with unstored value. Pressing UP jumps the value from 10 to 12 as 6 is not a valid value for this SV. (See Section 8, Setting Variable Descriptions.) No decimal point to right of 12 indicates it is not a stored value.

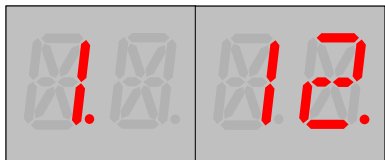

Figure 6d: SV with new stored value. Selecting this unstored value will store it, and a decimal point appears to its right indicating it is the stored value.

7.2 Navigating SVs

1. Use the Navigation pushbuttons (UP, DOWN, SELECT, BACK – see **Figure 4**) and the Display to move among SVs. A light touch is best.
2. Use UP and DOWN to move forward and backward among SVs.
3. Holding down the UP and DOWN pushbuttons will move rapidly through SVs in the direction indicated.
4. UP and DOWN pushbuttons “wrap around” between the highest and lowest SV. Unused SVs are skipped.
5. Pressing the SELECT pushbutton stops navigation among SVs and displays the stored value of the displayed SV. SV value can now be changed as described in “Changing SV Values” below. See **Figure 6b**.
6. Returning the 3-way Mode Switch to **A** or **C** position exits Settings Mode.

7.3 Changing SV Values

1. When the SV value is displayed, use the four pushbuttons (UP, DOWN, SELECT, BACK) and the Display to select a value for the current SV.
2. Use UP and DOWN to increase or decrease the displayed SV value. See **Figures 6b** and **6c**.
3. Holding down UP and DOWN pushbuttons will move rapidly through values in the direction indicated.
4. UP and DOWN pushbuttons “wrap around” between the highest and lowest value. Unused SV values are skipped.
5. Pressing the SELECT pushbutton will store the displayed value for this SV. A decimal point appears to the right of the value to indicate it is the new stored value. See **Figure 6d**.
6. Pressing the BACK pushbutton will stop display of values and return to navigating SVs as described above. See **Figure 6a**.
7. Returning the 3-way Mode Switch to **A** or **C** position exits Settings Mode.

7.4 Bit-Wise SV Values

SVs 11 through 17 turn features on or off by storing a one or zero in a particular bit position. See SV 15 for a good example.

To avoid fancy arithmetic, these bit-wise SVs have an additional level of navigation. See **Figure 7**. Here it is step by step:

1. Navigate to the desired SV with UP and DOWN. See **Figure 7a**.
2. Press SELECT. The Bit Number is displayed. See **Figure 7b**.

3. Navigate to the desired Bit Number (UP, DOWN). See **Figure 7c**.
4. Press SELECT. The Bit value is displayed. See **Figure 7d**.
5. UP and DOWN will move the Bit value between 0 and 1. Press SELECT to store the displayed value. See **Figure 7e**.
6. BACK will stop display of Bit values and return to navigating Bit Numbers. See **Figures 7b and 7c**.

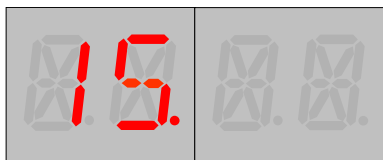

Figure 7a: Navigate to desired SV.
SV 15, our target, is displayed. Compare to **Figure 6a**.

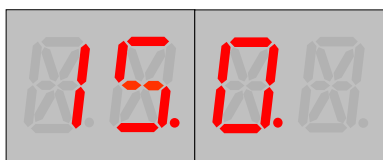

Figure 7b: Bit Number displayed.
SELECT causes Bit Number to display with decimal point to its right. Bit 0 is the first Bit Number displayed.

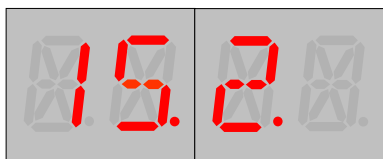

Figure 7c: Navigate to desired Bit.
UP and DOWN are used to navigate to our target, Bit 2. This bit turns on Crew Slang.

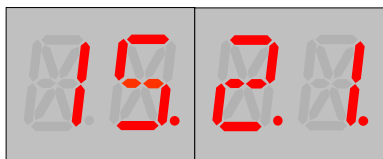

Figure 7d: Current Bit value.
SELECT causes Bit value to display. "1" is the current stored value – Slang is on.

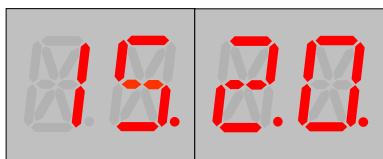

Figure 7e: New stored Bit value.
UP/DOWN move back and forth between "0" and "1" Bit values. SELECT stores new value of "0" – Slang is off.

7.5 Returning to Factory Default

While in Settings Mode, you can return your Defect Detector SVs to their original values:

1. While navigating SVs, depress and hold the BACK pushbutton.

2. While holding down BACK, depress and hold down both the UP and DOWN pushbuttons at the same time.
3. After 4 seconds, the Defect Detector will show *RST and say "Reset".
4. Release all three pushbuttons. All SVs are now reset to original values.

7.6 Viewing Session Axle Count

While in Settings Mode, you can view total axles counted since power on:

1. While navigating SVs, depress and hold the BACK pushbutton.
2. While holding down BACK, depress and hold down the SELECT pushbutton at the same time.
3. After 4 seconds, the Defect Detector will show and say the total axles since power up. The Detector will count up to 4095, then roll over to 0.
4. Release both pushbuttons to return to navigating SVs.

8. Setting Variable (SV) Descriptions

Visit our website (www.bouldercreekengineering.com/manuals.php) for worksheets to record your SV settings.

SV 1 – 6: Defect Probabilities

Description: The average number of 4-axle cars per defect. Value stored and displayed is 1/10 of the actual rate, so multiply by 10 for the true value. If more than one defect type is on, the defect occurrences will add. For example, if both Hotbox and Dragging Equipment are set to 100 (10 stored), you could expect one of each defect type every 100 cars, or a defect of either type roughly every 50 cars or so.

Valid Values: 0 (defect disabled), 3, 4, 5, 6, 8, 10, 12, 15, 20, 25, 30, 40, 50, 60, 80, 100, 120, 150, 200, 270, 400, 800

Examples: 3 = 30; 10 = 100; 800 = 8000 cars per defect

SV	Defect Type	Default
1	Hotbox	10 (=100)
2	Dragging Equipment	0 (disabled)
3	Sliding Wheel	0 (disabled)
4	High Car	0 (disabled)
5	Wide Load	0 (disabled)
6	Shifted Load	0 (disabled)

Note: This probability is an average. For example, with the default setting and after 5000 cars have passed, you would expect to have seen about 50 hotboxes. But just as in real life, you can't predict when stuff will happen!

SV 7: Axle Sensor Separation

Description: The distance in scale feet between the two Axle Sensors.

Valid Values: 4 – 235, minimum of 20 suggested

Default Value: 44 scale feet

Examples: 20 scale ft. between sensors; 44 scale ft. between sensors

SV 8: Engine Axles

Description: Engine axles on front of train. Defects will not be assigned to these axles during normal operation – and avoided if possible for a “Next Train” event – if SV 15, Bit 4 is active.

Valid Values: 4- 235

Default Value: 8 axles

Examples: 4 axles, 12 axles, 18 axles

SV 9: Temperature

Description: The average temperature in Automated Voice Report Mode. Temperature will randomly vary +/- 4 degrees around this value and change only slightly from train to train.

Valid Values: 4– 235 (keep it real!)

Default Value: 50 degrees

Example: 32 degrees will produce a range of 28 – 36 degrees

SV 10: Speed Limit

Description: The speed limit in MPH for this section of track. Trains traveling too fast or slow will trigger crew comments in Crew Mode operation. The crew will signal the engineman to stop the train if the speed is more than 20 MPH over this value.

Valid Values: 4 - 99

Default Value: 40 MPH

Examples: 15 MPH, 45 MPH, 59 MPH

SV 11,12: Output Behavior

Description: Defines Output 1 and Output 2 behavior with individual bits.

Outputs are **on** or **off**. Outputs are either pulled to ground or open circuit when **on** and **off** as set by Bit 2.

- SV 11 controls Output 1
- SV 12 controls Output 2

Default Value: 01000010

Bit 7	6	5	4	3	2	1	Bit 0
Opp 1^a	Clr Rpt	ClrTime	DbITime^b	Reserved	Invert	Output Action	

Bit 7 **Opposite Output 1**

^aValid for SV 12 Output 2 only, ignored for SV 11 Output 1
1 = Output 2 puts out opposite value of Output 1, **off** if Output 1 is **on** and vice versa. The rest of this SV is ignored.
0 = Output 2 is independent of Output 1 and the rest of this SV determines Output 2 behavior (**default**)

Bit 6 **Clear on Report**

1 = Output is cleared when **Report** input activated (**default**)
0 = Output is not cleared **off** when **Report** input activated

Bit 5 **Clear on Time**

1 = Output is cleared after time set by Bit 4
0 = Output is not cleared after time set by Bit 4 (**default**)

Bit 4 **Double Time**

^bValue in SV 11 applies to both Output 1 and Output 2.
Bit 4 in SV 12 is ignored.
1 = Output is cleared after 60 seconds
0 = Output is cleared after 30 seconds (**default**)

Bit 3 **Reserved** (ignored)

Bit 2 **Invert**

1 = Output pulled to ground when **off**, open circuit when **on**
0 = Output open circuit when **off**, pulled to ground when **on** (**def**)

Bits 1, 0 **Output Action**

11 = Flash **on/off** when train has defects, patterned by SV 13/14
10 = **On** steady only when train has defects (**default**)
01 = **On** steady only when train has no defects
00 = **On** steady when train has no defects or output is cleared

SV 13,14: Output Flash Pattern

Description: Defines Output 1 and Output 2 flash patterns.

Corresponding Output Behavior SV must be set to Flash.
Each bit turns the output **on** or **off** for 1/8 of a second, with 1 = **on** and 0 = **off**. Bit 0 controls the first 1/8 sec, Bit 1 the second 1/8 sec, etc. Pattern repeats every second.

- SV 13 controls Output 1
- SV 14 controls Output 2

Default Value: 00001111 (on 1/2 sec, off 1/2 sec)

Examples: 00001111 is **on** for 1/2 sec., then **off** for 1/2 sec.
01010101 is **on/off** 4 times per second

SV 15: Control

Description: Defines miscellaneous control values with individual bits.

Default Value: 00111110

Bit 7	6	5	4	3	2	1	Bit 0
Mute Err	Max Defects	No Eng	Display	Slang	RR Dir	Mute	

Bit 7 Mute Error Messages

- 1 = Error messages unspoken (See Section 6.6)
- 0 = Error messages spoken (**default**)

Bits 6, 5 Maximum Defects per Train

- 11 = 3 max def/train
- 10 = 2 max def/train
- 01 = 1 max def/train (**default**)
- 00 = defects will not be reported

Bit 4 No Engine

- 1 = Engine axles will not receive defects per SV 8 (**default**)
- 0 = Engine axles can receive defects

Bit 3 Visual Display Enable

- 1 = Messages always visually displayed (**default**)
- 0 = Message displayed only when **Report** push button depressed

Bit 2 Crew Slang Enable

- 1 = Railroad slang enabled in Train Crew reports (**default**)
- 0 = Railroad slang disabled in Train Crew reports

Bit 1 Railroad Direction

- 1 = East/West railroad (**default**)
- 0 = North/South railroad

Bit 0 Mute All

- 1 = Sound disabled (recommended for visual display option)
- 0 = Sound enabled (**default**)

SV 16: OK Message Control

Description: Turns OK Message components on/off with individual bits.
See **SV 20-90** below for related information.

Default Value: 00011111

Bit 7	6	5	4	3	2	1	Bit 0
Reserved	Axle	Speed	Length	Temp	Close		

Bits 7-5 **Reserved** (ignored)

Bit 4 Axle Count

- 1 = Axle Count spoken in message trailer (**default**)
- 0 = Axle Count not spoken in message trailer

Bit 3 Train Speed

- 1 = Train Speed spoken in message trailer (**default**)
- 0 = Train Speed not spoken in message trailer

Bit 2 Train Length

- 1 = Train Length spoken in message trailer (**default**)
- 0 = Train Length not spoken in message trailer

Bit 1 Temperature

- 1 = Temperature spoken in message trailer (**default**)
- 0 = Temperature not spoken in message trailer

Bit 0 Close Statement

- 1 = Close statement spoken in message trailer (**default**)
- 0 = Close statement not spoken in message trailer

SV 17: Defect Message Control

Description: Turns **Defect Message** components on/off with individual bits. See **SV 20-90** below for related information.

Default Value: 01000001

Bit 7	6	5	4	3	2	1	Bit 0
Rsrvd	First	Repeat	Reserved		Temp	Close	

Bit 7 **Reserved** (ignored)

Bit 6 **“First” Always Spoken Before First Defect**

1 = Defect report always numbers defects beginning with “First” (**default**)

0 = Defect report only numbers defects if more than one for a train

Bit 5 **Repeat Defect Report**

1 = Defect report is spoken twice in message body

0 = Defect report is spoken only once in message body (**default**)

Bits 4-2 **Reserved** (ignored)

Bit 1 **Temperature**

1 = Temperature spoken in message trailer

0 = Temperature not spoken in message trailer (**default**)

Bit 0 **Close Statement**

1 = Close statement spoken in message trailer (**default**)

0 = Close statement not spoken in message trailer

SV 20 – 90: Custom Automated Message SVs

Description: A message will play after a train passes a Defect Detector operating in Automated Trackside Voice Report mode. You can customize the messages your Defect Detector plays.

Messages are a mix of user-programmed segments and Detector-generated reports. Separate words and phrases are programmed into the message segments with these 71 SVs.

There are two message types: an **OK Message** for trains with no defects, and a **Defect Message** for trains with defects. Each message first plays its Header, then Body, and finally Trailer. The SVs relate to messages as shown here (Detector-generated reports are in gray):

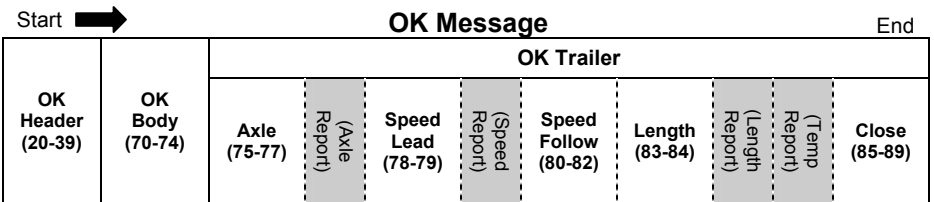

Notice that a **Defect Message** is simpler and has fewer user-programmed segments than an **OK Message**.

Valid Values: 0 – FF

Method: Enter values into SVs from the **Word & Phrase Table (Section 9)**, beginning with the first SV for the segment. If all available segment values are not filled, enter “FF” in the first unused SV – the Defect Detector will fill in “FF” for the remaining unused SV values. (“FF” indicates an empty value.)

Example: If you program values in SV 20 – SV 39 thus:

SV	20	21	22	23	24	25	26	27	28	29
Value	2	16	3	15	8	0	42	27	34	31
SV	30	31	32	33	34	35	36	37	38	39
Value	2E	60	43	34	FF	FF	FF	FF	FF	FF

You will hear the following **OK Message Header**:

A T AND S F RAILROAD, MILEPOST 3 2 POINT 4, TRACK NUMBER TWO

Here are the Automated Message SVs and their defaults:

SV 20 – 39: OK Header

SVs	Message Type	Segment	Number of Values
20 – 39	OK	Header	20

Default Values: DEFECT DETECTOR

SV	20	21	22	23	24	25	26	27	28	29
Value	4A	3F	FF	FF	FF	FF	FF	FF	FF	FF
SV	30	31	32	33	34	35	36	37	38	39
Value	FF	FF	FF	FF	FF	FF	FF	FF	FF	FF

SV 40 – 69: Defect Header

SVs	Message Type	Segment	Number of Values
40 – 69	Defect	Header	30

Default Values: DEFECT DETECTOR BEEP STOP TRAIN BEEP

SV	40	41	42	43	44	45	46	47	48	49
Value	4A	3F	3C	5D	61	3C	FF	FF	FF	FF
SV	50	51	52	53	54	55	56	57	58	59
Value	FF	FF	FF	FF	FF	FF	FF	FF	FF	FF
SV	60	61	62	63	64	65	66	67	68	69
Value	FF	FF	FF	FF	FF	FF	FF	FF	FF	FF

SV 70 – 74: OK Body

SVs	Message Type	Segment	Number of Values
70 – 74	OK	Body	5

Default Values: NO DEFECTS

SV	70	71	72	73	74
Value	38	FF	FF	FF	FF

SV 75 – 77: Axle

SVs	Message Type	Segment	Number of Values
75 – 77	OK	Trailer	3

Default Values: TOTAL AXLE COUNT

SV	75	76	77
Value	5F	47	49

SV 78 – 79: Speed – Lead

SVs	Message Type	Segment	Number of Values
78 – 79	OK	Trailer	2

Default Values: TRAIN SPEED

SV	78	79
Value	61	5C

SV 80 – 82: Speed – Follow

SVs	Message Type	Segment	Number of Values
80 – 82	OK	Header	3

Default Values: (empty)

SV	80	81	82
Value	FF	FF	FF

SV 83 – 84: Length

SVs	Message Type	Segment	Number of Values
83 – 84	OK	Trailer	2

Default Values: TRAIN LENGTH

SV	83	84
Value	61	4E

SV 85 – 89: Close

SVs	Message Type	Segment	Number of Values
85 – 89	Both	Trailer	5

Default Values: END_OF_TRANSMISSION

SV	85	86	87	88	89
Value	39	FF	FF	FF	FF

SV 90: Defect Ending

SVs	Message Type	Segment	Number of Values
90	Defect	Trailer	1

Default Values: (empty)

SV	90
Value	FF

9. Word & Phrase Table

Word or Phrase	Value
A	2
B	4
C	5
D	6
E	7
F	8
G	9
H	A
I	B
J	C
K	D
L	E
M	F
N	10
O	11
P	12
Q	13
R	14
S	15
T	16
U	17
V	18
W	19
X	1A
Y	1B
Z	1C
ZERO	35
ONE	30
TWO	34
THREE	27
FOUR	2E
FIVE	2C
SIX	32
SEVEN	22
EIGHT	2B
NINE	2F
TEN	33
ELEVEN	1E
TWELVE	28
THIRTEEN	25
FOURTEEN	20
FIFTEEN	1F

Word or Phrase	Value
SIXTEEN	24
SEVENTEEN	23
EIGHTEEN	1D
NINETEEN	21
TWENTY	29
THIRTY	26
FORTY	2D
ALARM	46
AND	3
AXLE	47
AXLES	48
BEEP (TONE)	3C
CENTRAL	70
CONRAIL	71
COUNT	49
DEFECT	4A
DEGREES	67
DETECTOR	3F
DOT	2A
DRAGGING	40
EAST	4B
EASTERN	68
END_OF_TRANSMISSION	39
EQUIPMENT	41
FIRST	4C
FROM_HEAD_OF_TRAIN	3A
GREAT	72
HAVE_A_SAFE_DAY	3B
HIGH_CAR	36
HOTBOX	4D
LENGTH	4E
LOAD	4F
MAIN	50
MILEPOST	42
MILES_PER_HOUR	37
NEAR	51
NEW_YORK	69
NICKEL_PLATE	6A
NO_DEFECTS	38
NORFOLK	73
NORTH	52
NORTHERN	6B

Word or Phrase	Value
NUMBER	43
OF	74
ON	53
OUT	54
OVER	55
PAUSE (SILENCE)	3D
PENN	75
PENNSYLVANIA	6C
POINT	31
RAIL	56
RAILROAD	0
RAILWAY	1
REPEAT	57
SECOND	44
SHIFTED	58
SIDE	59
SLIDING	5A
SOUTH	5B

Word or Phrase	Value
SOUTHERN	6D
SPEED	5C
STOP	5D
SYSTEM	76
TEMPERATURE	66
THIRD	5E
TOTAL	5F
TRACK	60
TRAIN	61
WABASH	6E
WEST	62
WESTERN	6F
WHEEL	63
WHISTLE (TONE)	3E
WIDE	64
WORKING	45
YOUR	65

Support & Service

If you have problems with your **TrainBoss™ Defect Detector**, please consult our website www.bouldercreekengineering.com. If you need additional help, please contact us at support@bouldercreekengineering.com.

Your Defect Detector can be repaired with a charge for parts and labor. Please contact support@bouldercreekengineering.com for a cost estimate on non-warranty repairs before sending product to us.

Limited Warranty

Boulder Creek Engineering, LLC warrants its products to be free of defects in materials and workmanship for a period of **one (1) year** from the purchase date. Defective product received by Boulder Creek Engineering during the warranty period will be repaired or replaced at our option. You must pay shipping to and from Boulder Creek Engineering.

This warranty does not cover damage resulting from negligent installation, improper operation, or unauthorized repair or modification. Removal of the heat shrink voids this warranty. Boulder Creek Engineering makes no other warranty of any kind, expressed or implied. In no event shall Boulder Creek Engineering be liable for incidental or consequential damages.

For warranty service, please contact Boulder Creek Engineering for a Return Merchandise Authorization (RMA) number. Product must be shipped to Boulder Creek Engineering with dated proof of purchase (your receipt).



2525 Arapahoe Ave.
Suite E4-605
Boulder, CO 80302

(303) 443-5784
support@bouldercreekengineering.com